



VACUUM STONEMAGNET SM

Handy, powerful and cordless vacuum lifting device for laying of dense stone slabs, concrete elements, pipes and similar. Can be used on all kind of lifting equipment.

- ▶ Specially designed and equipped for heavy duty work on the construction site.
- ▶ For special purposes, there are different suction plates available, which can be attached to the SM easily.

Standard Specifications:

- ▶ Robust and compact main body, with integrated suspension for crane hook and quick change device for the suction plate.
- ▶ Powered by rechargeable, exchangeable 12 V battery. Power saving control system makes battery lasting for one whole working day. Battery can be exchanged within seconds. Battery charge indicator.

- ▶ Security features: Flashing light to warn on insufficient low pressure, automatic control system to start the vacuum pump after loss of pressure, manometer, high volume vacuum storage tank.

- ▶ Standard suction plate 580 x 280 mm with special seal system, exchangeable within seconds without the use of glue or tools. No damage to the seal when setting on sharp edges for long time (no "supports" necessary).

Special features:

The SM is equipped with 2 vacuum-pumps as standard. When handling dense products, only one pump is used. On slightly porous material, or when quick cycle time is required, the second pump can be switched on by the TURBO switch.

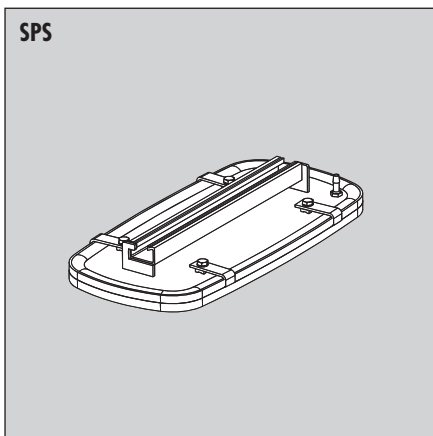

VACUUM STONEMAGNET SM - basic unit -

Type	Drive	Dead Weight kg (lbs)		Order-Number
SM [Ⓢ]	by 12 V battery	35 (78)	without suction plate	5272.0002

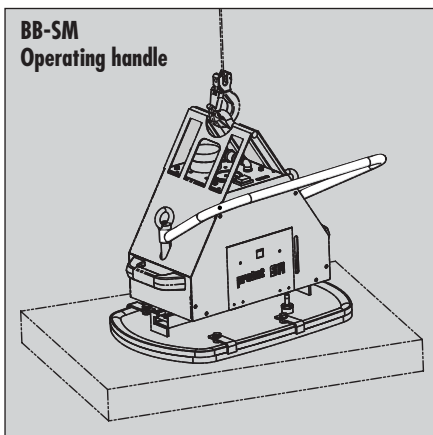

Accessories

Type	Description	Order-Number
SPS 90-SM [Ⓢ]	Suction plate, carrying approx. 90 kg* (200 lbs)* Dimensions approx. 300 x 200 mm (11 ³ / ₄ " x 7 ³ / ₄ "	4272.0009
SPS 200-SM [Ⓢ]	Suction plate, carrying approx. 200 kg* (440 lbs)* Dimensions approx. 580 x 280 mm (22 ³ / ₄ " x 11")	4272.0001
SPS 400-SM [Ⓢ] (for heavy loads)	Suction plate, carrying approx. 400 kg* (880 lbs)* Dimensions approx. 750 x 260 mm (29 ¹ / ₂ " x 10 ¹ / ₄ "	4272.0002
SM-Battery	Spare storage battery, 24 Ah, 12 V	2420.0008
SM-LG Battery charging device 220 V / 12 V	Battery charging device w/overload protection and charging current limiting. Housing is water and dust-proof.	2420.0016
SM-BB Operating handle [Ⓢ]	(also for retrofitting)	4272.0063
Highly wear-resistant replacement seal	for SPS 90 SM for SPS 200 SM for SPS 400 SM	4250.0023 4272.0004 4272.0005
Easy to attach without glueing		

Special suction plates, for example for pipes, on request.

* Value at 500 mbar low pressure

Ⓢ Durable surface protection by galvanizing